

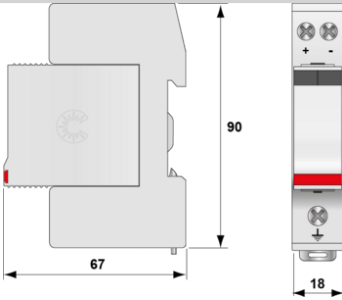

CITEL

DS220-12DC



Electrical Characteristics		
Network		DC or PV network 12Vdc
Max. DC operating voltage	Uc	24 Vdc
Max. load current @25°C	IL	50 A
Total Maximum discharge current max. total withstand @ 8/20 μs	I _{max} Total	40 kA
Protection mode(s)		Common mode
Protection level +/PE (-/PE) @ I _n (8/20μs)	Up	250 V
Mechanical Characteristics		
Technology		MOV
Connection to Network		By screw terminals: 1.5-10mm ² (actives wires) and 2.5-25mm ² (ground)
Format		Plug-in modular box
Failsafe mode		Disconnection from DC network
Weight		0.109 kg
Standards		
Certification		UL 497B
Part number		
390101		

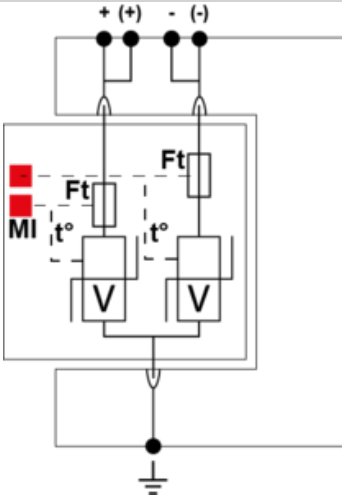

V: High-energy varistor
 Ft: Thermal fuse
 t*: Thermal disconnection system
 MI: Disconnection indicator

