

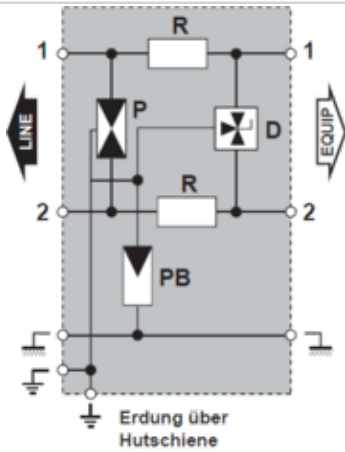

- ↳ Hybrid SAD-GDT Technology
- ↳ Compact 6mm module
- ↳ UL497B LISTED
- ↳ 10kA I_{max} (1x 8/20us)
- ↳ 2.5kA I_{imp} (2x 10/350us)
- ↳ 5kA I_n (10x 8/20us)
- ↳ 2W+SHIELD+G
- ↳ Common/Differential mode protection

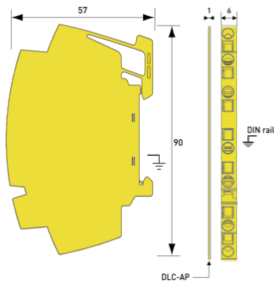

SIL3
IEC61508



P : 3-poliger Gasableiter
Pb : 2-poliger Gasableiter
R : Widerstand oder Spule
D : Diode

G : Descargador tripolar
Gb : Descargador bipolar
R : Resistor
D : Diodo limitador

Características eléctricas	
Red	LS, 4-20 mA
Tensión DC máx. de operación	Uc 28 Vdc
Frecuencia máx.	f max. > 20 MHz
Perdida de inserción	< 1 dB
Corriente máx. De línea @25°C	IL 300 mA
Corriente de choque Prueba 10/350µs x 2 - categoría D1	Iimp 2.5 kA
Corriente de descarga nominal X-C (Línea/Tierra) Prueba 8/20µs x 10 - categoría C2	I _n L/PE 5 kA
Resistencia en línea (± 10%)	4.7 Ohm
DATA SPD TYPE	UL497B LISTED
TENSION	(V) 24
WIRES	2W+Shield+G
LINE CURRENT MAX	(A) 0.3
AMBIENT MIN	(C) -50
AMBIENT MAX	(C) +85
RESIDUAL VOLTAGE	(V) 20
MCOV	(V) 8/72/72
IN	(kA) 5
IMAX	(kA) 10
Iimp	(kA) 2.5
DATA SPEED	(Mbps) 10/100/1000
FREQUENCY	(MHz) >20
INSERTION LOSS (@ FREQ)	(db) < 1
Características mecánicas	
Tecnología	GDT+Diodo limitador
Conexión a la red	Terminal de primavera 2.5 mm ² / AWG 13 (sólido o trenzado)
Formato	Caja DIN desenchufable
Modo de fallo	Corto-circuito
Weight	0.029 kg
TECNOLOGIA	SAD-GDT
CONFIGURACION DE RED	1 pair
FORMA DE CONEXION	Screw Terminal
MONTAJE	Din Rail
MATERIAL	Thermoplastic UL94-V0
NEMA RATING (IP RATING)	NEMA 2 (IP20)
DIMENSIONS	See diagram
WEIGHT	0.30 lbs
Normas	
Certificación	UL listed / SIL
UL STANDARD	UL497B
UL CATEGORY	QVGQ
UL FILE NUMBER	E184939
NORMAS	IEC 61643-11, NOM-003-SCFI-2014, NOM-001-SCFI-1993
ENVIRONMENTAL STANDARDS	ROHS
Código	
641113	

