

# MP Enclosed Surge Protective Device

## Installation and Operating Manual

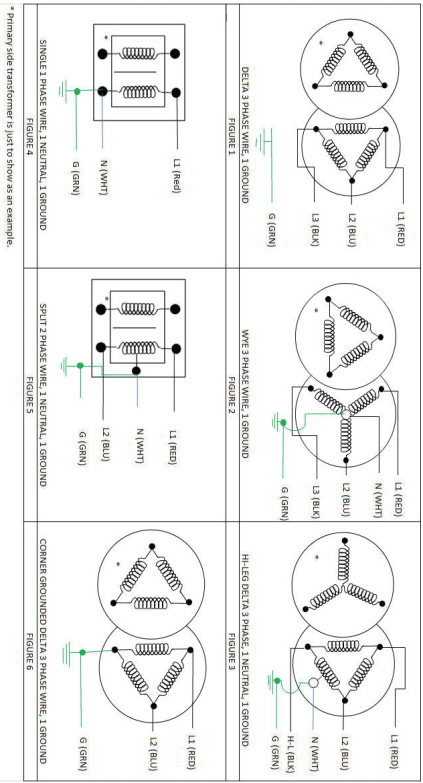



\*Primary side transformer is just to show as an example.

System	MPXXX[-C, -L, -H, -LC, -HC]- 120 T	MPXXX[-C, -L, -H, -LC, -HC]- 120 Y	MPXXX[-C, -L, -H, -LC, -HC]- 240 Y	MPXXX[-C, -L, -H, -LC, -HC]- 240 DCT	MPXXX[-C, -L, -H, -LC, -HC]- 240 D	MPXXX[-C, -L, -H, -LC, -HC]- 277 Y	MPXXX[-C, -L, -H, -LC, -HC]- 347 Y	MPXXX[-C, -L, -H, -LC, -HC]- 480 D
120T (FIGURE 5)	●							
120Y (FIGURE 2)		●						
240Y (FIGURE 2)			●					
240D (FIGURE 3)				●				
240DCT (FIGURE 3)					●			
277Y (FIGURE 2)						●		
347Y (FIGURE 2)							●	
480D (FIGURE 3)								●
Max. VPR L-N	700	700	1000	700	-	1000	1800	1800
Max. VPR L-G	700	700	1200	700	1200	1800	1800	1800
Max. VPR L-L	1000	1000	1800	1000	1800	1800	3000	3000
Max. VPR N-G	700	700	1000	700	-	1000	1800	-
MCOV	150	150	320	150	320	320	550	550
In	20MA 8/20L							
SCCR	200KA							

XXXX can be:  
 80  
 100  
 160  
 200

\*Represents max Per Phase

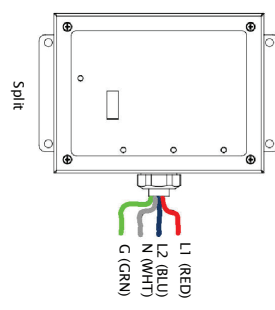
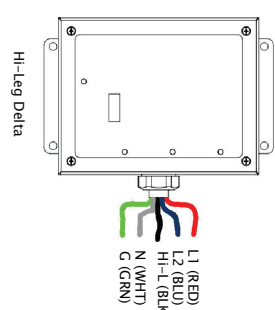
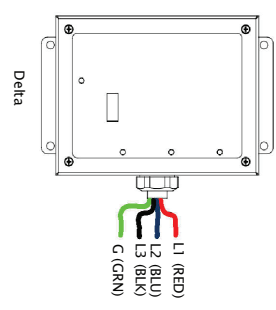
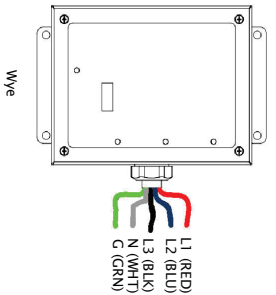

MP series Standard Application

## Mechanical Drawings

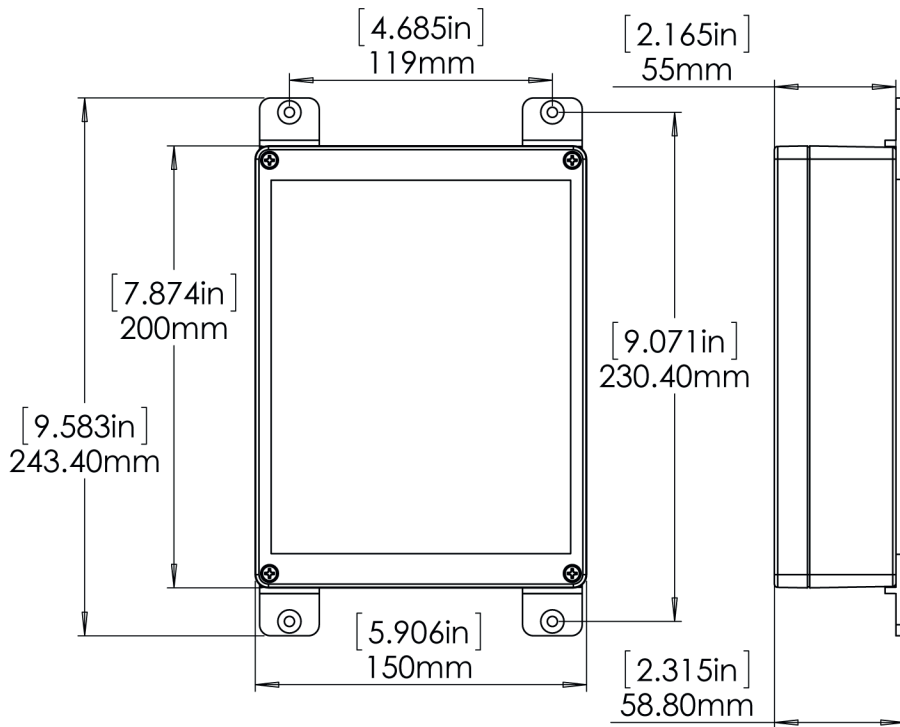

## Installation and Operating Manual

### MP Series Enclosure Type 1 & 2 AC Surge Protection Device

READING AND UNDERSTANDING THIS MANUAL IN ITS ENTIRETY IS ESSENTIAL PRIOR TO INSTALLING AND COMMISSIONING THE SURGE PROTECTIVE DEVICE



### Safety Precautions

The electrical system on which this surge protective device will be installed must be in proper working condition. Consult with trained personnel before proceeding with the installation, if there are any questions regarding system status. The potential exists for this unit to be damaged if the requirements of this manual are not followed. Failure to comply with the applicable requirements of this manual may result in warranty void. Removal of warranty label will result in warranty void.

### Introduction

Proper installation of CITEL MP series surge protective device is essential to maximize performance and effective protection. Please read the entire installation manual process prior before installing the device. This manual does not replace national and local codes, please verify with electrical codes.



### WARNING

#### Hazard of electric shock

- This equipment must only be installed and serviced by qualified electrical personnel.
- Turn off all power supplying this equipment before working on or inside equipment.
- Always use a properly rated voltage sensing device to confirm power is off.
- This equipment must be effectively grounded per all applicable codes.

Failure to follow these instructions may result in serious injury or death

## Product Description

CITEL MPseries products are designed to protect electrical equipment's from damaging effects of transient voltages created from direct and indirect lightning strikes, equipment switching or other cause of disturbances. Metal Oxide Varistors (MOV) technology is utilized to achieve a high level of protection performance. Each MP series comes standard with status light, alarm auxiliary contacts.

## Characteristics

Series	MP80	MP100	MP160	MP200
Maximum discharge current	I <sub>max</sub> 80 kA	100 kA	160 kA	200 kA
Type of network				
120/240 Vac Split Phase 3Ph+G	MP80-120T	MP100-120T	MP160-120T	MP200-120T
120/208 Vac Wye 3Ph/N+G	MP80-120Y	MP100-120Y	MP160-120Y	MP200-120Y
220/380 Vac Wye 3Ph/N+G	MP80-220Y	MP100-220Y	MP160-220Y	MP200-220Y
277/480 Vac Wye 3Ph/N+G	MP80-277Y	MP100-277Y	MP160-277Y	MP200-277Y
240/415 Vac Wye 3Ph/N+G	MP80-240Y	MP100-240Y	MP160-240Y	MP200-240Y
120/120/240 Vac Hi-Leg Delta 3Ph/N G	MP80-240DCT	MP100-240DCT	MP160-240DCT	MP200-240DCT
240 Vac Delta 3Ph+G	MP80-240D	MP100-240D	MP160-240D	MP200-240D
347/600 Vac Wye 3Ph/N+G	MP80-347Y	MP100-347Y	MP160-347Y	MP200-347Y
480 Vac Delta 3Ph+G	MP80-480D	MP100-480D	MP160-480D	MP200-480D
Protection modes	L/N - L/G - N/G - L/L			
UL short-circuit current rating	200 kA			
Standards compliance	UL1449 4th Edition and Type 1 and Type 2			
<b>Safety</b>				
Thermal disconnect	Internal to each component			
Electrical disconnect	Internal to each surge protector			
Failure indicators	LED			
<b>Mechanical Characteristics</b>				
Relative Humidity	5% to 95% non condensing			
Housing material	Painted Steel or Stainless Steel ( Depending on Version)			
Operating temperature	-40/+85 °C			
Mounting	Wall mounting by screws (not supplied)			
Connection to AC network	Hard-Wired			
Dimensions (H x L x D)	7.86 X 5.895 X 2.180 in			
<b>Specific features</b>				
Disconnection switch	No			

In the event of product end of life of the MP series, installed MOV's will safety disconnect from the circuit, will give visual indication to the user.



### WARNING

Verify that a proper neutral-ground bond has been made when power is supplied from an upstream transformer or any other type of separately derived power source.

- Power must be disconnected prior to installation, inspection or servicing. Failure to do so may cause injury, death and/or equipment damage.

- Failure to provide this bond, as required by NEC 250.30, will void the warranty and can result in elevated phase to ground source voltage potentials. These voltages can cause damage to electrical equipment, pose a fire hazard or a safety hazard such as electrical shock, injury or death.

## Application

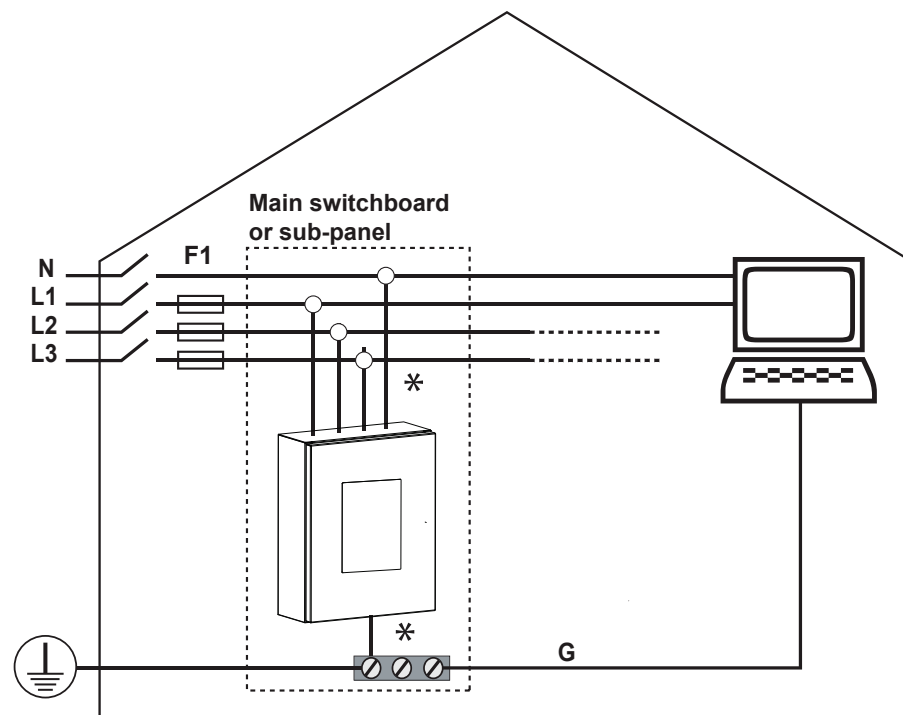

\* Shortest distance possible

## MP Display

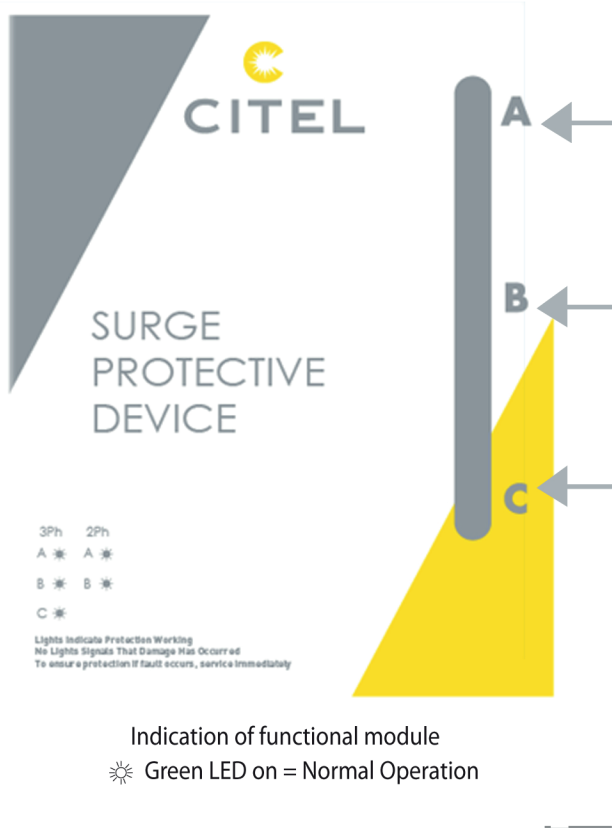

## Product Selection

Selecting the proper surge protection device can be a complicated task. Consult with qualified personnel to ensure the electrical system is in good working condition and proper sizing for an SPD. Reference

## Product Pre-Installation

Prior to installing your new MP series SPD, please read and understand the following safety instructions of this installation manual. Ensure that all safety precautions are taken and follow all applicable electrical codes.

1. Power must be disconnected before installing to circuit panel. Failure to do so may lead to serious injury or death and equipment damage.
2. Ensure that the selected MP series product is the correct electrical system and voltage rating for your application.
3. National Electric Code (NEC) Article 285 states that Type 2 SPDs may only be placed on the load side of the main breaker or fuse at each utility service entrance.
4. Per National Electric Code (NEC), ensure that proper neutral-ground bond has been made when power is supplied from an upstream transformer or any type of separately derived power source. NEC Article 250.30 this bond must be placed in all 3 phases WYE, Single phase and Split phase system.

## Installation

### Mounting Instruction

CITELE MP series enclosures are constructed with NEMA 4X (description below) enclosure. The dimensions and drawing can be viewed on [page 8](#). The MP series enclosure can be installed on indoor/outdoor locations as close as possible to the protected circuit. Avoid long wire runs from the SPD to the circuit, as it will reduce performance. Make sure that the surface of where the unit is to be installed on is stable and capable of bearing the load.

Wire	Color
Ground	Green or Green/Yellow
Neutral	White
Hot	Red, Blue, Black (Hi-Leg)

### Recommended Circuit Breaker/Fuse

Wire Size	Circuit Breaker/Fuse
#10 AWG	30A rms

## Enclosure

### Type 4X - Plastic

Enclosures constructed for either indoor or outdoor use to provide a degree of protection to personnel against access to hazardous parts; to provide a degree of protection of the equipment inside the enclosure against ingress of solid foreign objects (windblown dust); to provide a degree of protection with respect to harmful effects on the equipment due to the ingress of water (rain, sleet, snow, splashing water, and hose directed water); that provides an additional level of protection against corrosion; and that will be undamaged by the external formation of ice on the enclosure.

**IMPORTANT! Remember to keep conductor lead length to a minimum; 3ft or less. The minimum length of wire is defined by the limit of the enclosure. A minimum gauge of 10 AWG is to be used.**

## Maintenance

Preventive maintenance is not specified, however, the MP Series should be checked periodically by a qualified personnel to ensure proper operation. When inspecting the unit, check the connection integrity to the network.

## Diagnostics

Upon energizing the MP series unit, check to ensure proper operation and should show all green. Check to make sure the voltage electrical network is in good working order and all instruction in this manual has been followed. If issues remain the same please contact CITEL for technical support at 800-248-3548 or visit our website at [www.citel.us](http://www.citel.us).

## Alarm Conditions – Contact Status

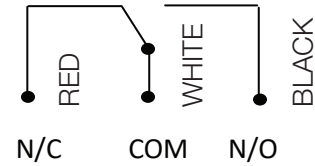

1. SPD de-energized
2. SPD energized, fault
3. NC-COM (Red-White)
4. NO-COM (Black-White)

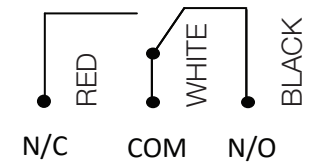

1. SPD energized, Status OK (All Green LEDs)
2. NC-COM (Red-White)
3. NO-COM (Black-White)

Connection: #24-16 AWG (0.2mm – 1.5.mm<sup>2</sup>)

Rating: 0.5A, 125VAC, 1A 30Vdc

## Troubleshooting

Check for proper connection from the unit to the circuit, check unit that it properly match circuit voltage network for operation. If all display LEDs are green, the unit is properly working. If no lights check for proper line voltage and neutral connection. If still no light unit needs replacement.