

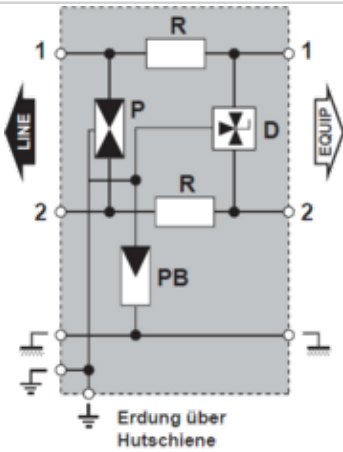

- ↳ Hybrid SAD-GDT Technology
- ↳ Compact 6mm module
- ↳ UL497B LISTED
- ↳ 10kA I_{max} (1x 8/20us)
- ↳ 2.5kA I_{imp} (2x 10/350us)
- ↳ 5kA I_n (10x 8/20us)
- ↳ 2W+SHIELD+G
- ↳ Common/Differential mode protection

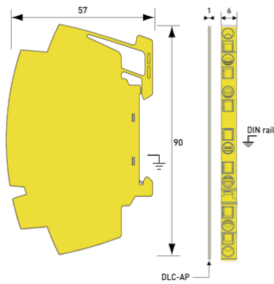

SIL3
IEC61508



P : 3-poliger Gasableiter
 Pb : 2-poliger Gasableiter
 R : Widerstand oder Spule
 D : Diode

G: 3-electrode gas tube
 Gb: 2-electrode gas tube
 R: Resistor
 D: Clamping diode

Electrical Characteristics

Network		LS, 4-20 mA
Max. DC operating voltage	Uc	28 Vdc
Max. frequency	f max.	> 20 MHz
Insertion loss		< 1 dB
Max. load current @25°C	IL	300 mA
Protection Level C3 (10/1000µs), 300 applications@10 A, X-X (Line/Line)	Up	40 V
Protection level C3 (10/1000µs), 300 applications@10 A, X-C (Line/Earth)	Up	40 V
Impulse current 2 x 10/350µs Test - D1 Category	Iimp	2.5 kA
Nominal Discharge Current, X-C (Line/Earth) 8/20µs Test x 10 - C2 Category	In L/PE	5 kA
Line resistance (± 10%)		4.7 Ohm
DATA SPD TYPE		UL497B LISTED
VOLTS	(V)	24
WIRES		2W+Shield+G
LINE CURRENT MAX	(A)	0.3
AMBIENT MIN	(C)	-50
AMBIENT MAX	(C)	+85
RESIDUAL VOLTAGE	(V)	20
MCOV	(V)	8/72/72
I _N 10 impulses 8/20µs	(kA)	5
I _{MAX} 8/20µs	(kA)	10
I _{imp} 10/350µs	(kA)	2.5
DATA SPEED	(Mbps)	10/100/1000
FREQUENCY	(MHz)	>20
INSERTION LOSS (@ FREQ)	(db)	< 1

Mechanical Characteristics

Technology		GDT+TVS diode
Connection to Network		By spring terminal - max. cross section 2.5mm ² / AWG 13 (solid or stranded)
Format		DIN box
Failsafe mode		Short-circuit
Weight		0.029 kg
TECHNOLOGY		SAD-GDT
NETWORK CONFIGURATION		1 pair
CONNECTION METHOD		Screw Terminal
MOUNTING		Din Rail
MATERIAL		Thermoplastic UL94-V0
NEMA RATING (IP RATING)		NEMA 2 (IP20)
DIMENSIONS		See diagram
WEIGHT		0.30 lbs

Standards

Certification		UL listed / SIL
UL STANDARD		UL497B
UL CATEGORY		QVGQ
UL FILE NUMBER		E184939
STANDARDS		IEC 61643-11, NOM-003-SCFI-2014, NOM-001-SCFI-1993
ENVIRONMENTAL STANDARDS		ROHS

Part number

641113

