

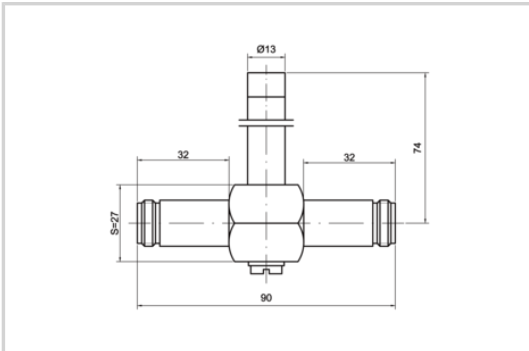

- Quarter wave coaxial protector type 7/16
- Frequency : 870-960 MHz
- Low insertion loss
- $I_{max} > 50 \text{ kA}$
- Maintenance free
- Bi-directional
- IP65



Electrical Characteristics		
Frequency range	f	870-960 MHz
Insertion loss		< 0.2 dB
Return loss		> 20 dB
Impedance		50 ohms
VSWR		<1.2:1
Max. load current @25°C	IL	10 A
Protection mode(s)		Common mode
Impulse current <i>2 x 10/350µs Test - D1 Category</i>	limp	25 kA
Nominal discharge current <i>C2 Category</i>	In	25 kA
Max Power @f mini.		436 W
PIM 3rd order (2x20W)		< -160 dBc
DC Pass		No
RF Power <i>Maximum</i>	W	1500.0000
Return Loss <i>Minimum</i>	db	>20
VSWR <i>Maximum</i>	:1	<1.2:1
Max Total Discharge Current <i>I_{max} (8/20µs x 1)</i>	kA	40.0000
Max Discharge Current <i>I_{max} (8/20µs x 1)</i>	kA	40.0000
Installation		
Operating Temperature <i>Min</i>	°C	-45.0000
Operating Temperature <i>Max</i>	°C	85.0000
Operating Temperature <i>Min</i>	°F	-50.0000
Operating Temperature <i>Max</i>	°F	85.0000
Operating Relative Humidity <i>Max</i>	%RH	Can be submerged
Operating Altitude <i>Min</i>	Ft	2000.0000
Operating Altitude <i>Max</i>	Ft	6500.0000
Housing/Enclosure material		Cu, Zn, Sn plated Brass
Mounting		Bracket or through hole
IP Environmental rating <i>IP</i>		IP65
NEMA Environmental rating <i>NEMA</i>		NEMA 4
Installation Location		Indoor / outdoor
Accessories		BK
Product Dimension <i>L</i>	mm	90.0000
Product Dimension <i>L</i>	In	3.5430
Miscellaneous		
Individual Pack		No
Storage Temperature <i>Min</i>	°C	-40.0000
Storage Temperature <i>Max</i>	°C	85.0000
Storage Temperature <i>Min</i>	°F	-40.0000
Storage Temperature <i>Max</i>	°F	85.0000
Mechanical Characteristics		
Technology		Quarter Wave
Connection to Network		Connector N Female/Female
Failsafe mode		Without
Contacts		Bronze/Surface Au-Ag
Insulation material		PTFE
Standards		
RohS compliance		Yes
Part number		
621124		