



CITEL

MP100-480DCT



- Multi-TMOV Technology
- UL1449 Type 1 LISTED
- 132kA I_{max} Surge Current Rating
- Visual fault indicator (optional remote contacts)
- 10-Year warranty

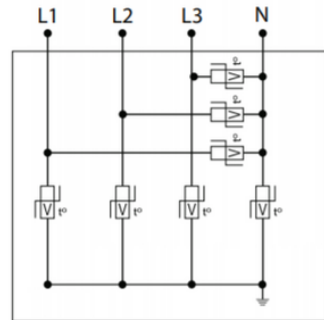

Electrical Characteristics	
POWER SPD TYPE	UL1449 TYPE 1 LISTED
VOLTS	(V) 240/480
AC/DC/DC PV/RF	AC
PHASE	(PH) 3H
AMPS	(A) N/A
AMBIENT MIN	(C) -35
AMBIENT MAX	(C) 85
MODES	L-L, L-N, L-G, N-G, H-L, H-N, H-G
VPR	(V) 1800/1000/1200/1000(3000/1000/1200)
MCOV	(V) 690/320/320/320(870/550/550)
IN	(kA) 20
15 impulses 8/20 μ s	
IMAX	(kA) 132
8/20 μ s	
Mechanical Characteristics	
TECHNOLOGY	Multi-TMOV
NETWORK CONFIGURATION	3PH, 4W+G, Hi-Leg Delta
CONNECTION METHOD	36" #10 AWG LEADS
MOUNTING	FLANGE MOUNT
MATERIAL	Polycarbonate
NEMA RATING (IP RATING)	4X (IP67)
FAIL-SAFE BEHAVIOR	Yes, no upstream over current protection required
REAL-TIME DIAGNOSTICS	LED. Optional remote contacts.
DIMENSIONS	See diagram
WEIGHT	6 lbs
Standards	
UL STANDARD	UL1449 5th Edition
UL CATEGORY	VZCA, VZCA7
UL FILE NUMBER	E326289
STANDARDS	NOM-003-SCFI-2014
ENVIRONMENTAL STANDARDS	ROHS
Part number	
891816	

