

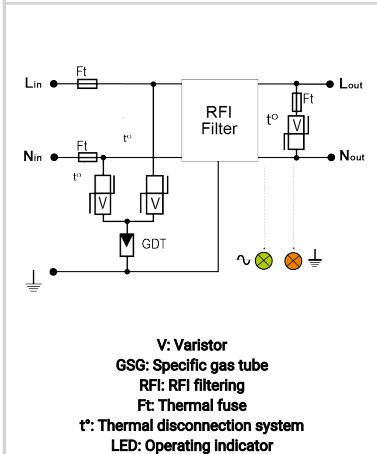

CITEL

MSB-130HF/US

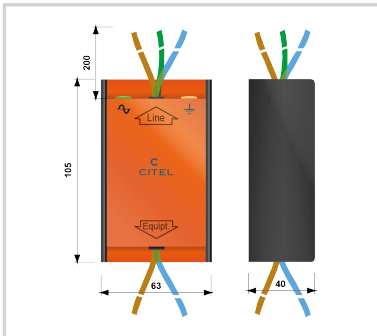

Electrical Characteristics	
Network	230/400V
Max. AC operating voltage	Uc 255 Vac
Max. load current @25°C	IL 16 A
Max. discharge current <i>max. withstand @ 8/20 μs by pole</i>	I _{max} 10 kA
Protection mode(s)	Common/Differential mode
Mechanical Characteristics	
Technology	MOV+GDT+Filter
Connection to Network	Wires
Mounting	Wall
Operating temperature	Tu -40/+85°C
Protection rating	IP20
Failsafe mode	Disconnection and AC line cut-off
CONNECTION METHOD	15" #14 AWG LEADS
Standards	
Certification	
Part number	
400	

