

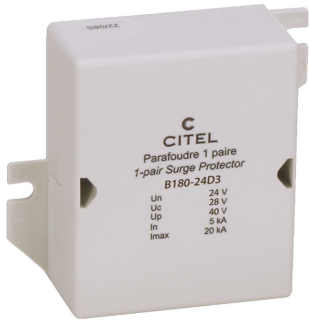

CITEL

DATA LINE SPD - UL497B - I_{max} 20kA - I_n 5kA

B180-24D3



- ▶ Hybrid SAD-GDT Technology
- ▶ Common/Differential Mode Protection
- ▶ UL497B
- ▶ 20kA I_{max}
- ▶ 5kA I_{imp}
- ▶ 2.5kA I_n

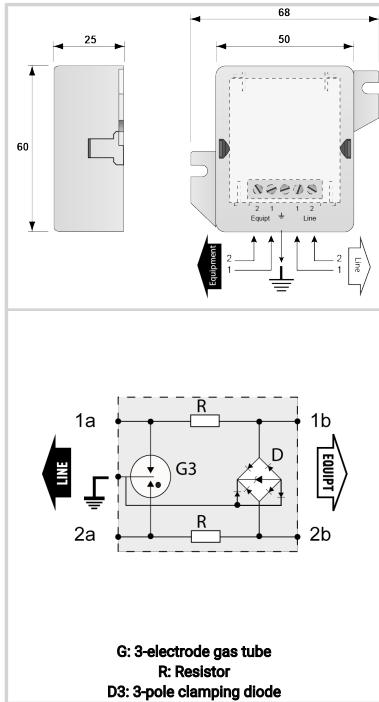

Electrical Characteristics		
Network		4-20mA, 24V
Nominal line voltage	Un	24 V
Max. DC operating voltage	Uc	28 Vdc
Max. frequency	f max.	20 MHz
Insertion loss		< 1 dB
Max. discharge current <i>max. withstand @ 8/20 μs by pole</i>	I _{max}	20 kA
Nominal Discharge Current <i>C2 (1.2/50μs / 8/20μs), 10 applications, X-X (Line/Line)</i>	I _n	5 kA
Protection Level <i>C3 (10/1000μs), 300 applications@10 A, Y-Y (Line/Line)</i>	Up	40 V
Impulse current <i>2 x 10/350μs Test - D1 Category</i>	I _{imp}	2.5 kA
Max. Load current	IL	300 mA
Mechanical Characteristics		
Technology		GDT + R + Diode
Connection to Network		By screw terminal: cross section 0.4-1.5mm ²
Format		Wall mounting box
Operating temperature	Tu	-40/+85°C
Protection rating		IP20
Failsafe mode		Short-circuit - transmission cut-off - fault mode 2
NETWORK CONFIGURATION		2W+G
MATERIAL		Thermoplastic UL94-V0
DIMENSIONS		See diagram
Standards		
Certification		UL listed
UL STANDARD		UL497B
UL CATEGORY		QVGQ
UL FILE NUMBER		E184939
STANDARDS		IEC 61643-11, NOM-003-SCFI-2014, NOM-001-SCFI-1993
ENVIRONMENTAL STANDARDS		ROHS
Part number		
510302		

